

EAB16RT

The platform is equipped with an integrated high capacity battery pack. As a result, it is silent and emissions free, the ideal solution for working in enclosed spaces. It is also equipped with 4 drive wheels for greater stability on any surface. The boom folds for transport so that the vehicle can be shipped in a container.

STANDARD EQUIPMENT

- Modular design with high compatibility of pieces within the whole range
- Proportional controls
- Thumb rocker steering
- Flashing light
- Horn
- Hour counter
- Harsh Environment Kits
- 12V DC Auxiliary Power

PERFORMANCE

- Front oscillating axles to match the terrain irregularities granting optimal adherence to the ground
- 2 Wheels Steering
- Four-wheel drive
- Positive traction four wheel drive
- 360° rotation (continuous)

BASKET

- Self levelling platform
- Rotating basket +/-90°
- Power to platform

SAFETY

- Drive enable system
- Platform load sense system
- On-board diagnostics system
- Tilt indicator with alarm
- Crushing protection
- Emergency lowering system

BATTERY

- TIANNENG - Lead-acid battery
- Powersource : 48V/375Ah
- Charger : 48VDC/60A
- Monophase 220V
- Recharge cycle from 0 to 100% (hours)*: 5

APPLICAZIONI PRINCIPALI



Edilizia



Grandi
Eventi



Manutenzione
di aeromobili,
Riparazione navale



Impiantistica



Oil & gas



Restauro

EAB16RT

Max. working height	16.07m
Max. basket height	14.07 m
Articulation point	7.25 m
Max. reach	8.74 m
Below-ground height	1.06 m
Below-ground reach	7.25 m
Max. platform load capacity	250 kg
Max. Occupants	2
Max. gradeability (stowed)	40%
Max. working slope	X-5°/Y-5°
Max. wind speed	12.5m/s
Turning radius (outside)	4.49 m
Turning radius (inside)	2.92 m
Turret rotation (continuous)	360°
Jib type	Regular
Jib length	1,50 m
Jib vertical rotation	132°
Basket width	0.79 m
Basket length	1.83 m
Basket rotation	180°
Total weight	7,780 kg
Travel speed (closed config.)	6.0km/h
Travel speed (working config.)	1.1km/h
Tyres	315/55 D20
Hydraulic tank capacity	145 l
Battery Type	TIANNENG - Lead-acid battery
Powersource	48V/375Ah
Charger	48VDC/60A
Charger type	Monophase 220V
Recharge cycle from 0 to 100% (hours)*	5
Driving motors	34VAC/9kW
Lifting motors	34VAC/13kW
Emergency power system	-
Transmission	Hydrostatic

*Experimental calculation. The count is affected by climate and usage of the machine.

STANDARDS COMPLIANCE: EN 280, ANSI/SAIA A92.20

LOAD CHART

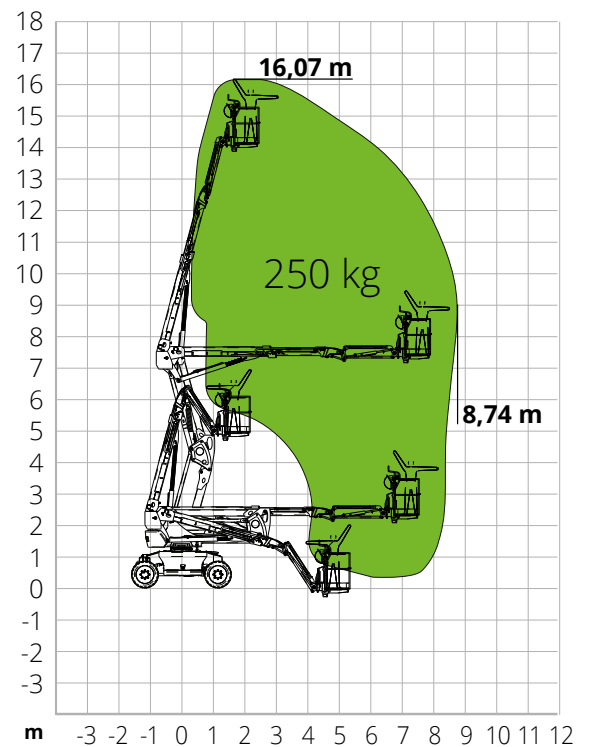

DIMENSIONS

A Platform length	7.05 m
Platform length (transport)	5.19 m
B Platform width (tyres)	2.33 m
Platform width (transport)	2.33 m
C Platform height	2.55 m
Platform height (transport)	2.57 m
E Wheelbase	2.30 m
Tailswing	0.19 m
D Ground clearance	0.31 m

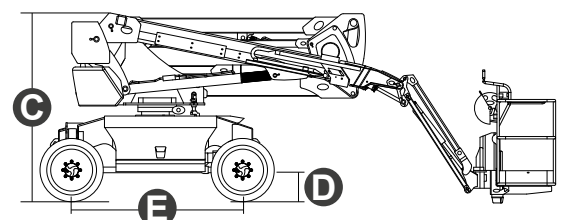
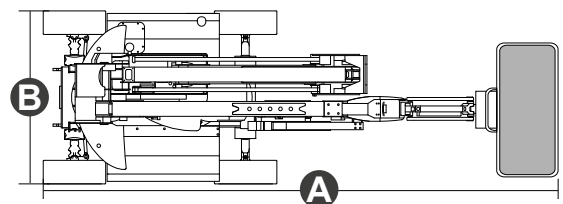

#LIFTDIFFERENT

www.magnith.com



The data in this brochure are provided for the purposes of information and subject to change without notice.